

Basic Intelligence Processing Space

By Bernd Schmeikal

Abstract

This paper investigates a universal creative system. Originally, this was referred to by its creator as an *autonomic string manipulation system*. Forty years ago, it was capable of such important operations as tetracoding (TTC) and binary *basic intellector processing* (BIP). After going deeper into the set of possible transformations, in both a sequential and a parallel manner, Joel Isaacson and Louis Kauffman had brought this down to the essential action of *Recursive Distinctioning* (RD). Considering the dual process of *antecursive conflation*, we can unpack a given creation – like a page taken out from a libretto – and trace it back to some initial headlines. We unpack the creation of our Minkowskian space-time with its geometric algebra, and show how it can be made a material representative of a BIP. So, after clarifying a few issues of ideographing, we state that the processes BIP, *digital image processing*, and TTC by RD, which were invented and investigated by Joel Isaacson, are real articulations of the natural space-time with its material systems of interacting particles. That is to say, our universe may be a representation of Isaacson's system, and entertainingly, with his US Patent specification 4,286,330, it seems he has patented creation.

Keywords: Universal creative systems, autonomic string manipulation, intellector processor, Recursive Distinctioning, antecursive conflation, Minkowski algebra, image processing, primordial space creation, retinoid cortical space, standard model of particle physics.

Prologue

This paper discusses a universal, dialectic, intelligent process, whose creator, 40 years ago, endowed it with some clumsy-looking names like *autonomic string-manipulation system* and *basic intellector processing* (BIP). This humble, dynamic system, featuring Hegel's triadic phenomenology of mind,¹ is very creative. It is now capable of reckoning up words in the retinoid visual cortex, and acts of creation, almost like the spill over from an unbounded living universe. In his early work, Joel Isaacson has used eleven *string-manipulation operations* to study the properties of his creation. Then, he realised that the tetracoding (TTC) and BIP were most important operations anyway. Kauffman and Isaacson have studied this system for a long time. They saw that there is a unary procedure on strings that is necessary for understanding creational processes, namely *Recursive Distinctioning* (RD).

My task is now to clarify some iconic coding issues brought in by the original operation of *ideographing* and to couple the creational process to theoretical physics. After all, we formerly based our synchronous template of the Minkowski space algebra and

¹ G. W. F. Hegel, *The Phenomenology of Mind*, trans. J. B. Baillie (London: George Allen & Unwin, 1966); G. W. F. Hegel, *The Phenomenology of Spirit*, trans. Terry Pinkard, terrypinkard.weebly.com/phenomenology-of-spirit-page.html (accessed February 13, 2016).

equations of motion on this operation; the standard model of high energy physics (HEPhy) and its symmetries are emerging results from such a recursive, scrambled, and entangled iterative process. I will show in exact terms how and why Isaacson's self-organizing string manipulation system creates synchronous iconic memories of objects in Minkowski algebra. Since I have found that the symmetries of space-time algebra are essentially those of the standard model of physics, it is reasonable to ask how an iteration may accidentally create an octet of the symmetric unitary group $SU(3)$. Indeed, both, the Clifford algebra of Minkowski space and the standard model of particle physics are deep and dynamically stable properties of some peculiar system of linear processing. Now, BIP and digital image processing (DIP) produce two important representations of results in our material world. The first is given by hardware implementations, the second by material assemblies in our familiar, relativistic space-time. It is interesting to note that the autonomic string-manipulation system, published with US Patent 4,286,330 on August 25, 1981, was a continuation of an application filed in April 1976. It referred to a related document having same title, filed in December 1975.² However, the "Dialectical Machine Vision" report came much later, namely in July 1987. It contained the ideographs of DIP cells combined with the hesitant denotation of "the 'alphabet' of the visual cortex," and some cryptic sentences on page 35: "For many years I have resisted describing DIP in 'neural' terms."

So, one would conclude that the retinoid ideographs were much younger than the autonomic string-manipulation system. But that would be wrong. On October 25, 2015, Joel wrote me, "I discovered the 16 icons a long time ago, in 1964. I was developing image processing techniques to analyse 2D digitised images. Two neighbourhoods have been available to me: 8-cell Moore neighbourhood and 4-cell von Neumann neighbourhood. The first led to 256 icons, where the 16 icons (that you now work with) were a subset. And the second led to 16 icons that are exactly identical with your 16 icons." There were some graphics with a description mailed to Louis Kauffman in 2012 when Louis was visiting at the Isaac Newton Institute in Cambridge. A special digitised radiograph was scanned by the film input into digital automatic computer and fed directly into the core memory of an IBM 7094 at NASA's Goddard Space Flight Center, Greenbelt, Maryland. It was thereafter analysed with the aid of a first tiny alphabet of 256 icons based on the 8-cell Moore neighbourhood and materialised by a Stromberg-Carlson 4020 microfilm recorder from NASA.

The computerised ideograph recorded fragments of the local boundaries of images. A little square has eight neighbouring squares. Each of them may be black or white. This makes a total of 256 combinations, the possible marks of a Moore filter. One goes from pixel to pixel, or in a font printout from character to character, and identifies the neighbourhood as one of those 256. Clearly, it is just as informative if one counts the von Neumann neighbourhoods. That makes no difference. However, the alphabet is restricted to the 16 necessary letters. Then, some of these icons were used, but their meaning as generators in algebraic modules was not yet explained. What is an advantage, mathematically, is that those 16 provide a basis of four, which can

² Application Ser. No. 674,658, filed April 7, 1976, and Disclosure Document entitled "Autonomic String-Manipulation System," No. 045773, filed on December 29, 1975.

immediately be identified within the geometric algebra of space-time. After all, logic connectives have a plane markedness. But then it was considered a virtue to proceed in a line with a minimal neighbourhood system to avoid perceptron-type models because of the disrepute attached to them,³ since Minsky and Papert had shown up their limitations. It was preferable to proceed with linear strings and a minimal neighbourhood, not in 3-line arrays or similar planar domains.

Components of Autonomic Intelligence

When, in April 1976, Joel Isaacson wrote a continuation of his autonomic string manipulation system, he wanted to design something extremely primitive, something that would take off with almost no processing capability, no memory or internal description of outer configurations, and that would process input regardless of type, classification, and complexity “in a blind, purposeless, and primitive fashion.” These were the words Isaacson chose in his 1981 patent specification.⁴ He must have felt that such a stupid processor, being aware of the presence of just a few nearest neighbours, would nevertheless, by the runtime, disclose what to us may appear as unterminated intelligence. To be precise, the *intellector process*, as it was called then, is not unbounded, but has definite boundaries; yet, its intelligence develops in an open-ended fashion. The beauty of the intelligent forms it (re)creates is continuing indefinitely, and while it creates various forms of remembrance, some gilded, some just surprising, it shows to us what Hegel once meant by his phenomenology of mind, with its reappearing and self-reproducing cycles driven by contradiction and synthesis. What once seemed so strange and superhuman, almost inhuman, all of a sudden turns out to be a self-evident feature of a most simple form of process driven by contact.

The basic processor manipulates strings of symbols or marks such as, say, the word 23f3f23trxff223. But we might just as well consider linear sequences of pixels with a grey level, or colour value, as inputs. What we need for manipulation is awareness or an identification of a given character. This character can be prehended or sensed or recorded by human beings, in which case it is also correlated with semiotic terms such as sign, icon, pictogram, index, token, ideogram, ideograph, and so forth. So we have sensual and cognitive attributes guiding a string. These perceptions and annotations allow us to refer to such a character as an objective element or a datum object.⁵ An element that cannot be perceived in that way is referred to as a *fantomark*. Strings containing fantomarks are called fantomark strings. We may denote it as basic intelligence if the processor acts according to the neighbourhood. So, we have fundamental operations acting on strings, reading them line by line. But we also have

³ Joel D. Isaacson, “Dialectical Machine Vision, Applications of Dialectical Signal-Processing to Multiple Sensor Technologies,” Report prepared for the Strategic Defense Initiative Organization (Arlington, VA: Office of Naval Research, 1987), 35.

⁴ Joel D. Isaacson, “Autonomic string-manipulation system,” US Patent No. 4286330 A, priority 1976, (publication date 1981), 8, patft.uspto.gov/netacgi/nph-Parser?Sect2=PTO1&Sect2=HITOFF&p=1&u=/netahtml/PTO/search-bool.html&r=1&f=G&l=50&d=PALL&RefSrch=yes&Query=PN/4286330. This was a continuation of application Ser. No. 674,658, filed April 7, 1976 with no cross-references to related applications, and a single relevant reference to a related disclosure document entitled Autonomic String-Manipulation System, No. 045773, filed on December 29, 1975.

⁵ Isaacson, “Autonomic string-manipulation system,” columns 3-4.

parallel, quasi-synchronous perception of the nearest neighbours. The identification of symbols in the immediate neighbourhood of an observed character in the linear sequence of marks in a string allows us to introduce techniques of RD, namely those in Isaacson's patent, and the procedures of *streaking* and TTC. Consider the closed string

2 3 f 3 f 2 3 t r x f f 2 2 3 having definite length 15

If we read from left to right and identify distinctions from neighbours, streaking brings on

0 0 0 0 0 0 0 0 0 1 0 1 0 0 with a zero appended to the end of a code sequence, and

A A A A A A A A A B C B C A are the tetracoded characters of the string.

For example, consider the second character in the original string, namely 3. It has left neighbour 2 and right neighbour *f*, both distinct from 3, hence tetracode *A*. Next, *f* has left and right neighbours 3, both distinct from *f*, hence tetracode *A*. We obtain a code mark *B* at location ... *x f f* ... because the left neighbour is distinct from *f* and the right neighbour is not distinct. Finally, we obtain mark *C* at location ... 2 2 3

The operations of streaking and TTC, on a topological basis of the nearest neighbours in linear sequences of marks, represent the most relevant methods in BIP. Clearly, it is possible to encode a tetracoded string by TTC. Isaacson gave the beautiful example of self-referential TTC of the word BEGINNING and the sentence SEE PERFECT CYCLE.⁶ We add the ENDING on the right of Table 1.

⁶ Isaacson, "Autonomic string-manipulation system," 3.

Table 1 a, b: Re-entering Strings to the Operations of TTC

(a)	1	2	3	4	5	6	7	8	9
00	B	E	G	I	N	N	I	N	G
01	A	A	A	A	B	C	A	A	A
02	B	D	D	C	A	A	B	D	C
03	A	B	C	A	B	C	A	A	A
04	A	A	A	A	A	A	B	D	C
05	B	D	D	D	D	C	A	A	A
06	A	B	D	D	C	A	B	D	C
07	A	A	B	C	A	A	A	A	A
08	B	C	A	A	B	D	D	D	C
09	A	A	B	C	A	B	D	C	A
10	B	C	A	A	A	A	A	A	A
11	A	A	B	D	D	D	D	D	C
12	B	C	A	B	D	D	D	C	A
13	A	A	A	A	B	D	C	A	A
14	B	D	D	C	A	A	A	B	C
15	A	B	C	A	B	D	C	A	A
16	A	A	A	A	A	A	A	B	C
17	B	D	D	D	D	D	C	A	A
18	A	B	D	D	D	C	A	B	C
19	A	A	B	D	C	A	A	A	A
20	B	C	A	A	A	B	D	D	C
21	A	A	B	D	C	A	B	C	A
22	B	C	A	A	A	A	A	A	A

(b)	1	2	3	4	5	6
00	E	N	D	I	N	G
01	A	A	A	A	A	A
02	B	D	D	D	D	C
03	A	B	D	D	C	A
04	A	A	B	C	A	A
05	B	C	A	A	B	C
06	A	A	B	C	A	A

The original invention, BIP, is concerned with unary operations on single strings, the operands. But it also allows for context-sensitive rewriting rules. Simultaneous application of rewriting rules to all characters in the operand is denoted as parallel. Sequential operation within the operand from the leftmost to the rightmost is called sequential. Figures 4A to E of the patent show how the array of tetracode strings can be transposed onto icons, broken lines, and streaks which can, again, be re-entered into a TTC procedure. Operations that are neither parallel nor strictly sequential are possible, and they are referred to as scrambled.

Notice that although we work with a minimal neighbourhood involving two neighbours only, we obtain fourfoldness through the four code-letters *A, B, C, D*. In image processing with constant line length, preserving parallel connection of lines, two neighbours with four letters pack the same information as four neighbours with two letters, that is, a von Neumann neighbourhood.

Ideographing

Linear Iconic Single Strings

As we obtained a code mark, *B*, say, at location ... *x f f* ... because the left neighbour was distinct from *f* and the right neighbour was not distinct, and we obtained a *C* mark at location ... *2 2 3* ..., it was easy to insert icons: □ for *B* and □ for *C*. Considering the *A* – no neighbour identical with the mark – as somehow isolated, we can substitute the *A* with □. The *D* indicated identical left and right marks. Hence, it seems good to indicate that opening towards both sides by the icon □. In this way, every single string can be rewritten as an iconic word. For instance, we obtain the following for the first three lines.⁷

⁷ Isaacson, "Autonomic string-manipulation system," 3, Figure 4b.

underestimated. In the second part of his preface to the report, Isaacson has listed some of these: *autonomic mode of processing, autonomic error correction, autonomic mode of 3-level memory, dialectical patterns, autonomic syllogistic inferences, limit cycles or attractors (Hegelian cycles), autonomic generations of palindromes, and complementarity of 4-letter strings*. The most important processing unit carries out an iterative triunation of the streak of a given string and its successors. This amounts to a Hegelizing of the process by an electronic circuit denoted as the *intellector* (Figure 2), which essentially operates on binary sequences of given length.

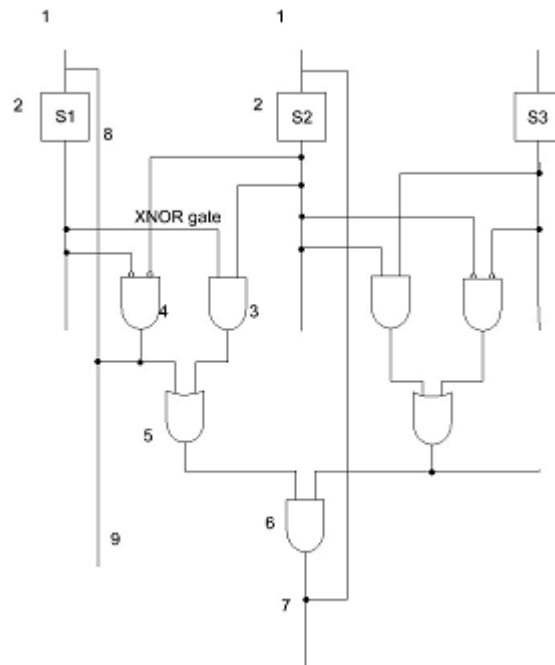

Figure 2: Basic circuitry of the intellector processor.

What was important for my own work was the appearance of the XNOR gates, the first from the left formed by Components 3, 4, and 5, because they represent a processing unit vector of the Clifford algebra of space-time. We shall come to this in a while. Isaacson described the important detail relating to XNOR gates and the circuit in Figure 7 of the patent. There are three binary signals (0 or 1) for A, B, and C at the input ports of s_1, s_2, s_3 . If all three signals are 0 or all three signals are 1, then the output is 1; otherwise, the output is 0. The logic expression describing the switching is given by $(A \text{ XNOR } B) \text{ AND } (B \text{ XNOR } C)$. This describes the operation *triunation* in the patent, and also Wolfram Rule 129. These are identical, but *triunation* predates Rule 129 by many years. Put in tandem, we get the combinatory circuitry of the whole of Figure 7 from the patent. As for oscillators, to realise the oscillators, we hold A and C fixed at 0 or at 1. If we set A and C at 0, we can start with $B_{(0)} = 0$ or $B_{(0)} = 1$.

For $B_{(0)} = 0$ we get the sequence:

$$B = 0, 1, 0, 1, 0, 1, \dots \quad (2)$$

For $B_{(0)} = 1$, we obtain

$$B = 1, 0, 1, 0, 1, 0, \dots$$

So, the smallest recursive triunation behaves like unitary oscillators, not unlike Kauffman's oscillatory sequences of the I and J.⁸ It turns out that these sequences can represent another generating unit of the Minkowski algebra. To understand the operations and dynamics of the autonomic string-manipulation system and the DIP, it is necessary to study the papers of Joel Isaacson. For the present, I just wish to refer to a few facts that concern the next section.

- there are signals;
- they are perceived as fourfold by TTC;
- they are rewritten by ideographs;
- they can be streaked;
- they are processed by serially connected XNOR gates;
- they begin ignorant, with almost no processing capability and no memory or internal description of outer configurations, and they process inputs in a blind, purposeless, and primitive fashion.

Real-World Components

Space-time, as a cognitive reality, represents a synchronous template, which I have constructed in order to coordinate real events. However, as a physical reality, space-time is an intelligent processing of energy. Years ago, when I tried to understand the relation between space-time and the standard model of HEPHY, it was not yet so clear that this processing had its own intelligence. But it was already evident that the central event under investigation was a processing of energy. It was known that space-time, be it explained by Euclidean space and separate time, or by relativistic, compound space-time, was connected with the concept of symmetry. In the simplest scenario, it would be natural to endow a Dreibein or a cube with an octahedral symmetry O_h or with a Bravais lattice, and, clearly, such an octahedral crystal – a diamond – would bring about a scattering of energy and of the observable degenerate energy levels. Could it be possible that space-time was responsible for the emergence of multiplets of elementary particles and energy spectra? These were the important questions, then. First, one had to identify the object that was worth being denoted as a mathematical agent of real space-time. Next, one had to find out about its symmetries. I felt that the symmetries of matter, the HEPHY standard, were essentially given by the symmetries of space-time. This led to a thirty-year endeavour, trying to conserve essential knowledge and at the same time to break away from the mainstream. It ultimately led to the book, *Decay of Motion – The Anti-Physics of Space-Time*.⁹ But the first breakthrough was published

⁸ Louis H. Kauffman, "Space and Time in Computation, Topology and Discrete Physics," In *Proceedings of the Workshop on Physics and Computation – PhysComp '94*, November 1994 (Dallas: IEEE Computer Society Press, 1995), 44-53.

⁹ Bernd Schmeikal, *Decay of Motion-The Anti-Physics of Space-time* (New York: Nova, 2014).

only in 1996 in a book about Clifford algebra, after I conversed with Pertti Lounesto.¹⁰ This was “The Generative Process of Space-Time.”¹¹

A picture arose in which several new ideas came together. First, it became clear that the complex matrices of the symmetric unitary group $SU(3, \mathbb{C})$ were elements of the matrix algebra $Mat(4, \mathbb{C})$, which represented the complexified Clifford algebra $\mathbb{C} \otimes Cl_{3,1}$. It could be that the standard model of HEPHY represented a space-time group rather than an auxiliary gauge group. In “Minimal Spin Gauge Theory,”¹² I investigated this alternative in greater detail, building on a preliminary inquiry of Roy Chisholm concerning “Unified Spin Gauge Theories and the Tetrahedral Structure of Idempotents.”¹³ It seemed to me that nature did not identify direction in such a definite way as we do in our laboratories. There was some basic uncertainty that disappeared in the stable arrangement of matter. Today, these features can be recognised as indicative of ignorance like that in the generative processes designed by Joel Isaacson.

Autonomic Intelligence

- Signals, marks, or polarised characters appear in diachronic succession.
- Processing is run in a blind, purposeless, and primitive fashion.
- No memory or internal description of outer configurations.

Physics

- Field quantization, fermions, condensates, and collapsing wave-functions are observed.
- Quantization is proceeding ignorant.
- No memory of the coding of outer configurations of coordinate base units.

Suppose, we had a triangle such as the one given by our image of a Euclidean Dreibein with three unit vectors (Figure 3).

¹⁰ Pertti found out that I was just about to rediscover Clifford algebra. I investigated the multivector groups of the Pauli algebra, that is, the Clifford algebra of the Euclidean 3-space. This algebra is generated by the three-dimensional Euclidean space, but can itself be considered as a vector space having dimension $2^3 = 8$. Surprisingly, the Minkowski space was a subspace of this orthogonal space generated by the Pauli matrices. I saw, then, what some had already known for a long time, that the four Dirac matrices used in theoretical physics also generated such a linear space of multivectors. This could be the 16-dimensional Clifford algebra of the Minkowski space, endowed with an indefinite metric $\{1,3\}$, what we denote as $Cl_{1,3}$, or it could be the Clifford algebra generated by the space in the opposite metric, the Lorentz metric, namely $Cl_{3,1}$. The latter has a 4×4 matrix representation, with real entries only. It is called Majorana algebra after Ettore Majorana, who first investigated nuclear weak decay with such real tools of differential geometry.

¹¹ Bernd Schmeikal, “The Generative Process of Space-Time and Strong Interaction – Quantum Numbers of Orientation,” in *Clifford Algebras with Numeric and Symbolic Computations*, ed. R. Ablamowicz, P. Lounesto, and J. M. Parra (Boston: Birkhäuser, 1996), 83-100.

¹² Bernd Schmeikal, “Minimal Spin Gauge Theory – Clifford Algebra and Quantumchromodynamics,” *Advances in Applied Clifford Algebra* 11, no. 1 (2001): 63-80.

¹³ J. S. R. Chisholm, “Unified Spin Gauge Theories of the Four Fundamental Forces,” in *Clifford Algebras and their Applications in Mathematical Physics*, ed. A. Micali et al. (Dordrecht: Kluwer, 1992), 363-70; J. S. R. Chisholm, “Tetrahedral Structure of Idempotents of the Clifford Algebra $Cl_{3,1}$,” in *Clifford Algebras and their Applications in Mathematical Physics*, ed. A. Micali et al. (Dordrecht: Kluwer, 1992), 27-32.

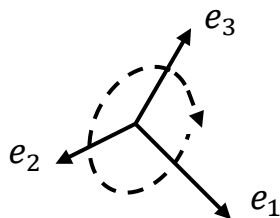

Figure 3: Rotation as recoding.

Consider a rotation that turns e_1 into e_2 , e_2 into e_3 , and e_3 into e_1 . Such a rotation, in a pure informatics sense, where nothing is known about such things as continuous motion, can be conceived as mere recoding. Mathematically, such a movement is represented by a permutation cycle (1, 2, 3). Now, consider that the process of nature in the deepest layer of dynamic phenomena cannot make those distinctions that we, the observers, are ready to make within the stratum of macrophysics. That could mean that the oscillators of field quantization, just like all the other movements we conceive of, do not distinguish between different base units of the Clifford algebra. I compile all such movements as *quantum motion* instead of as *quantum mechanics*. It might be that although the process of nature is ignorant of those differences the observers make within the macro-layers of the material world, it nevertheless brings those differences about. That would mean that the forces of nature, the ultraweak, the electromagnetic, the weak, and the strong interactions, give rise to the emergence of our concept of macroscopic space-time, in the form of a geometric Clifford algebra of the Minkowski space with its Lorentz metric, clearly, by making use not only of matter as space-time, but also of our brain cells, which somehow must incarnate this space-time as an inner neuronal arrangement. It seemed somewhat complicated to verify this idea, and I had to go slowly, step by step.

In Minimal Spin Gauge Theory, there were investigations of the relations between the orientation symmetries and the $SU(3)$, the action of reflections determined by the tetrahedral idempotent lattices. But, then, sociologically, it seemed, something had dazed us. The global reverberations and the anthropophobia before, during, and after the world wars had led to considerable rejections of insight and knowledge. These *social dislocations* probably had more important consequences for science than our later correcting measures of *quantum deformation*. Einstein had established an inner distance to quantum theory, and only lately had he realised the importance of Minkowski's work. Galina Weinstein confirmed what Gerhard Frey had said to me: "After he had received assistance from his friend, Marcel Grossmann, in late spring 1912, he found the appropriate starting point for a generalization"¹⁴ in terms of Minkowski's approach to space-time. He began to use the *line element* invariant under the Lorentz group. How come Einstein was side-tracked? Far off the beaten track of quantum mechanics, he began to describe the gravitational field by a metric tensor field. But if the properties of the space-time could describe gravitation, the ultraweak interaction, why could it not just as well, and even from the outset, describe the occurrence of quantum

¹⁴ Galina Weinstein, *Genesis of General Relativity – Discovery of General Relativity*, arxiv.org/ftp/arxiv/papers/1204/1204.3386.pdf (accessed February 4, 2016).

numbers of motion? I had to begin a back calculation. The following one is one of the many small, but important stages that had to be carried out to reach the aim. Particles should create their own space-time and HEPHY symmetries. If there existed the above fundamental uncertainty of quantum motion, we first had to investigate the algebraic object that carried out the transpositions of line elements in the basis of the Clifford algebra of the Minkowski space. This discrete group of 1,152 graded elements was found and was denoted as the *reorientation group* of the geometry $Cl_{3,1}$. It is a hyperoctahedral group generated by 24 multivectors having the form $s_{\chi k} = Id - 2f_{\chi k}$ ($\chi = 1, \dots, 6; k = 1, \dots, 4$) where the $f_{\chi k}$ are idempotents, primitive in the algebra $Cl_{3,1}$ having six colours χ and four indices determined by the basis of the Minkowski space. Accordingly, we take

$$\begin{aligned} f_1 &= \frac{1}{2}(Id + e_1)\frac{1}{2}(Id + e_{24}) & f_2 &= \frac{1}{2}(Id + e_1)\frac{1}{2}(Id - e_{24}) \\ f_3 &= \frac{1}{2}(Id - e_1)\frac{1}{2}(Id - e_{24}) & f_4 &= \frac{1}{2}(Id - e_1)\frac{1}{2}(Id + e_{24}) \end{aligned} \quad (3)$$

These primitive idempotents are Weyl's *erzeugende einheiten* for a linear subspace spanned by $ch_1 = span_{\mathbb{R}}\{Id, e_1, e_{24}, e_{124}\}$, and there are six such subspaces with positive definite metric $\{+ + + +\}$ in the Clifford algebra of the Minkowski space $\mathbb{R}^{3,1} \stackrel{\text{def}}{=} span_{\mathbb{R}}\{e_1, e_2, e_3, e_4\}$, having the indefinite signature of the Lorentz metric $\{+ + + -\}$. The quantities in the corners of Salomon's seal (Figure 4) span a commutative subspace, the *colour spaces* ch_{χ} . An idempotent primitive in $Cl_{3,1}$ represented by f_1 , endows ch_1 with a 1-norm. Take any $X = aId + be_1 + ce_{24} + de_{124} \in ch_1$ and verify that

$$f_1 X = (a + b + c + d)f_1 \text{ with 1-norm } L = a + b + c + d. \quad (4)$$

Therefore, we say that the $f_1 X$ provides an *eigenform* for a 1-norm.¹⁵ Take $L = a + b + c + d = 1$ to obtain $f_1 X = f_1$. It can be shown that each colour space ch_1, ch_2, \dots is isomorphic with the 4-fold real ring ${}^4\mathbb{R} = \mathbb{R} \oplus \mathbb{R} \oplus \mathbb{R} \oplus \mathbb{R}$.¹⁶ The proof goes as follows: Consider the idempotent

$$f = \frac{1}{2}(Id - e_1) \quad (5)$$

not primitive in the Minkowski algebra (but it is primitive in the Pauli algebra $Cl_{3,0}$) and the isospin

$$\Lambda_3 = \frac{1}{2}(e_{24} - e_{124}) \quad (6)$$

Both are elements in colour space ch_1 . For any natural number $n \in \mathbb{N}$ we verify the identities

¹⁵ Louis H. Kauffman, "Reflexivity and Eigenform – The Shape of Process," *Constructivist Foundations* 4, no. 3 (2009): 121-37; Heinz von Foerster, "Objects: Tokens for (Eigen-) Behaviors," in *Observing Systems*, Systems Inquiry Series (Seaside, CA: Intersystems Publications, 1981), 274-85.

¹⁶ Schmeikal, "Minimal Spin Gauge Theory," 63; Bernd Schmeikal, "Transposition in Clifford Algebra," in *Clifford Algebras – Applications to Mathematics Physics and Engineering*, ed. Rafal Ablamowicz (Boston: Birkhäuser, 2004), 351-72.

$$\Lambda_3^{2n} = f \text{ and } \Lambda_3^{2n-1} = \Lambda_3 \tag{7}$$

Therefore, the Clifford number Λ_3 represents a swap. The colourspace can now be decomposed into two ideals according to the equations

$$ch_1 = ch_1 f \oplus ch_1 \hat{f} = \mathcal{G}_1 \oplus \hat{\mathcal{G}}_1 \tag{8}$$

with main involuted \hat{f} , and spaces $\mathcal{G}_1 \stackrel{\text{def}}{=} span \{f, \Lambda_3\}$ and $\hat{\mathcal{G}}_1 \stackrel{\text{def}}{=} span \{\hat{f}, \hat{\Lambda}_3\}$. According to a theorem by Elié Cartan, all maximal abelian subalgebras of a semi-simple Lie algebra are mutually isomorphic. Further, the equations (7) imply that both \mathcal{G}_1 and $\hat{\mathcal{G}}_1$ are isomorphic with the small Clifford algebra $Cl_{1,0} := \{Id, e_1\} \simeq {}^2\mathbb{R} = \mathbb{R} \oplus \mathbb{R}$ – the double ring of real numbers. Therefore, due to Equation 8 we end up with a fundamental decomposition

$$ch_1 \simeq ch_\chi \simeq \mathbb{R} \oplus \mathbb{R} \oplus \mathbb{R} \oplus \mathbb{R} \text{ for each colourspace in the seal (see Figure 4).} \tag{9}$$

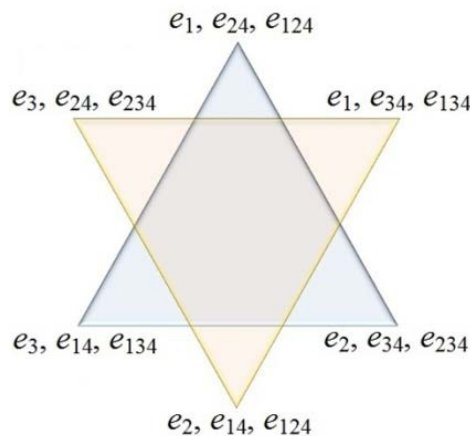

Figure 4: The seal of space-time – Cartan subalgebras of the motion-group.

Clearly, any colourspace can be spanned either by its orthogonal primitive idempotents or by its base units. If we consider the top of the seal, we represent the base units of ch_1 by the quadruples:

$$\begin{aligned} Id &= (+1, +1, +1, +1); e_1 = (+1, +1, -1, -1); \\ e_{24} &= (+1, -1, -1, +1); e_{124} = (+1, -1, +1, -1) \end{aligned} \tag{10}$$

With these numbers and Equation 3 we calculate the primitive idempotents $f_1 = (+1, 0, 0, 0)$; $f_2 = (0, +1, 0, 0)$; $f_3 = (0, 0, +1, 0)$; $f_4 = (0, 0, 0, +1)$; and \mathcal{G}_1 spanned by $f = (0, 0, +1, +1)$ and $\Lambda_3 = (0, 0, -1, +1)$. Now the story of the Minkowskian line elements, their metamorphosis, begins to become very interesting. In my books on primordial space, I had already investigated many important features of the HEPHY standard model space group. But now it had become possible to locate particles in a void without metric, and in such a way that they can represent the units of metric dynamic spaces themselves. In 2011, I heard Lou Kauffman speaking about eigenforms and

eigenvalues.¹⁷ That was on the occasion of the 100th birthday of Heinz von Foerster. Instead of using bivectors, Lou¹⁸ introduced the imaginary unit in the style of Rowan Hamilton,¹⁹ but developed the concept much further, by introducing the *iterant views* of dynamic systems for complex and quaternion arrays. Surprisingly, after having already restored the Dirac equation in this way in 1996, he now derived the discrete Schrödinger equation by the iterant algebra.²⁰ It did not take much more to seek a method to construct a geometric Clifford algebra with the aid of iterant algebra. This was first carried out in *Decay of Motion* and in two papers.²¹ Now it became possible to conceive of particles as fourfold strings of polarities. The affinity with Isaacson's streaks and time series of tetracodes became obvious.

See the analogy between the quad-locations²² and the ${}^4\mathbb{R}$ -representation of the base units of colourspace $ch_1 = span \{Id, e_1, e_{24}, e_{124}\}$. Due to the peculiar construction of the iterant algebra, we can identify the iterant views with units having different grades: a spatial unit, a space-time area, and a space-time volume.

$$e_1 := [+1, +1, -1, -1]; e_{24} := [+1, -1, -1, +1]; e_{124} := [+1, -1, +1, -1] \quad (11)$$

As we know, it is the trigonal transition among those iterants that brings out discrete colours, satisfying the unitary symmetry of the motion. On the other hand, the colourspace, being a commutative Cartan subalgebra of the $Cl_{3,1}$, is derived from the quaternion algebra by abstracting from the temporal order imposed on the iterants correlated with space ch_1 by the permutations φ, σ , and τ . In this sense, each colourspace $ch_\chi (\chi = 1, \dots, 6)$ turns out to be a *contemporised synchronous image* of the quaternion iterant temporal structure of relativistic quantum motion.

Space-Time Algebra from Its Logical Basis

Theorem:²³ The iterant algebra with four grades is isomorphic with the Clifford algebra $Cl_{3,1}$

Sketch of Proof: Consider the three real iterants e, f, g ; they are logic icons,

¹⁷ Louis H. Kauffman, "Eigenforms and Quantum Physics," *Cybernetics and Human Knowing* 18, no. 3-4 (2011): 111-21.

¹⁸ Louis H. Kauffman, "Imaginary Values in Mathematical Logic," in *Proceedings of the Seventeenth International Symposium on Multiple-Valued Logic* (Piscataway, NJ: IEEE, 1987), 282-89.

¹⁹ W. R. Hamilton, "Theory of Conjugate Functions, or Algebraic Couples; with a Preliminary and Elementary Essay on Algebra as the Science of Pure Time," *Transactions of the Royal Irish Academy* 1837, no. 17:293-422.

²⁰ Louis H. Kauffman, "Iterants, Fermions and Majorana Operators," in *Unified Field Mechanics, Natural Science Beyond the Veil of Spacetime — Proceedings of the IX Symposium Honoring Noted French Mathematical Physicist, Jean-Pierre Vigié*, Morgan State University, Baltimore, MD, November 16-19, 2014, ed. Richard L. Amoroso, Louis H. Kauffman and Peter Rowlands (Singapore: World Scientific Publishing, 2016), 1-32.

²¹ Bernd Schmeikal, "Four Forms Make a Universe," *Advances in Applied Clifford Algebra* 25, no. 1 (2015): 1-23, doi:10.1007/s00006-015-0551-z; Bernd Schmeikal, "Free Linear Iconic Calculus, AlgLog Part 1: Adjunction, Disconfirmation and Multiplication Tables," doi:10.13140/RG.2.1.2083.1841.

²² Schmeikal, "Four Forms Make a Universe," Table 12.

²³ This theorem is proved in Schmeikal, "Four Forms Make a Universe," as Theorem 18.

$$\sqsupset \simeq e = [+1, +1, -1, -1], \sqsubset \simeq f := [+1, -1, -1, +1], \bar{\sqsupset} \simeq g := [+1, -1, +1, -1] \quad (11)$$

together with the permutation operators $\sigma := (1\ 2)(3\ 4)$, $\varphi := (1\ 3)(2\ 4)$, $\tau := (1\ 4)(2\ 3)$. These transpositions of characters are generated by iteration time t and tangle time η . Sequences are iterated by iteration time and by tangle time, and are applied to iterants of degree 4. The iterant time t is represented by a permutation 4-cycle $(1\ 2\ 3\ 4)$ and the tangle time by a 2-cycle $(1\ 2)$. These two generate the symmetric group S_4 . We have equations

$$\begin{aligned} \sigma[a, b, c, d] &= [b, a, d, c]\sigma \\ \varphi[a, b, c, d] &= [c, d, a, b]\varphi \\ \tau[a, b, c, d] &= [d, c, b, a]\tau \end{aligned} \quad (12)$$

Transpositions φ, τ, σ can be derived from iterant and tangle-time operators in this order

$$\begin{aligned} \varphi &= t^2 = (1\ 2\ 3\ 4)(1\ 2\ 3\ 4) = (1\ 3)(2\ 4), && \text{portrayed as cycles} \\ \tau &= \eta\varphi\eta = (2\ 1)((1\ 3)(2\ 4))(2\ 1) = (1\ 4)(2\ 3), && \text{palindromic operation} \\ \sigma &= \tau\varphi \end{aligned} \quad (13)$$

Now there exist nine possibilities to let any permutation operator act on the unit iterants. Among these nine products, there are six quaternions. Among those there are the three we already know from the analysis of quad locations. Three of the nine squared give the identity Id . The nine terms are $e\sigma, e\varphi, e\tau, f\sigma, f\varphi, f\tau, g\sigma, g\varphi, g\tau$. The idea of proving the theorem is challenged when we understand why among these nine we have six instead of three quaternions. That is, there are indeed two basic quaternion spaces in the Clifford algebra of Minkowski space, namely, a triple of *bivectors* $\{e_{12}, e_{23}, e_{13}\}$ with definite signature $\{-1, -1, -1\}$ and a further triple of time-like, quasi *thermodynamic* quaternions with different grades, the time-space quaternions $\{e_4, e_{123}, e_{1234}\}$. If we place these two sets of quaternions in parallel, we can see

$$\begin{array}{ccc} e_{12} & e_4 & e_{124} \\ e_{23} & e_{123} & \Rightarrow e_1 \\ e_{13} & e_{1234} & e_{24} \end{array} \quad (14)$$

how both quaternion groups, by Clifford multiplication, are carried to the *angular momentum Cartan subalgebra*, that is, to the colour-space of the logic units. The Clifford product in each row gives a component of the first colour-space, each of which squared gives the identity. Therefore, it is reasonable to assume, say, that the four quantities $\sqsupset, \bar{\sqsupset}, \varphi, \tau$ generate a geometric algebra that includes even more than just two sets of quaternions. This could be the Clifford algebra $Cl_{3,1}$ of the Minkowski space. To abbreviate the proof, let us factor in how the quantities $\sqsupset, \sqsubset, \varphi, \tau$ interact.

Consider polarity strings e, f, g constituting the commutative algebra of a Klein-4 group; all the same the permutations σ, φ, τ satisfy the same algebra. The mixed products of

polarity strings and permutations commute or anti-commute.²⁴ For example, e commutes with σ , but f anticommutes with σ :

Use $e = [+1, +1, -1, -1]$, $\sigma := (1\ 2)(3\ 4)$, and (12): $\sigma[a, b, c, d] = [b, a, d, c]\sigma$, to get $\sigma e = (1\ 2)(3\ 4)[+1, +1, -1, -1] = [+1, +1, -1, -1]\sigma = e\sigma$; use $f := [+1, -1, -1, +1]$, $\sigma := (1\ 2)(3\ 4)$ and rule (12): $\sigma[a, b, c, d] = [b, a, d, c]\sigma$, to get $\sigma f = (1\ 2)(3\ 4)[+1, -1, -1, +1] = [-1, +1, +1, -1]\sigma = -f\sigma$; likewise, use $g := [+1, -1, +1, -1]$ and σ to verify $\sigma g = -g\sigma$; and so on until we get to $\tau g = -g\tau$. The result of exterior multiplication gives us the following representation of the Clifford algebra of Minkowski space $Cl_{3,1}$

$$\begin{array}{llll}
 Id & e_1 = e & e_2 = \varphi & e_3 = \tau f & (15) \\
 e_4 = f\varphi & e_{12} = e\varphi & e_{13} = g\tau & e_{14} = \varphi g & \\
 e_{23} = \sigma f & e_{24} = f & e_{34} = -\sigma & e_{123} = \sigma g & \\
 e_{124} = g & e_{134} = -\sigma e & e_{234} = -\tau & e_{1234} = \tau e &
 \end{array}$$

We verify the signature of the Minkowski space, but first of all its Cartan subalgebra using the XNOR:

$$\begin{array}{l}
 e_1 e_1 = e^2 = [+1, +1, -1, -1](\equiv)[+1, +1, -1, -1] = [+1, +1, +1, +1] = Id \\
 f^2 = [+1, -1, -1, +1](\equiv)[+1, -1, -1, +1] = Id \\
 g^2 = [+1, -1, +1, -1](\equiv)[+1, -1, +1, -1] = Id
 \end{array} \quad (16)$$

Here, we indicate that component-wise multiplication is brought forth by logical equivalence of sequences. Also we have

$$\begin{array}{l}
 e_3 e_3 = \tau f \tau f = f \tau \tau f = f Id f = f f Id = Id Id = Id \\
 e_4 e_4 = f \varphi f \varphi = -\varphi f f \varphi = -\varphi Id \varphi = -\varphi \varphi Id = -Id Id = -Id
 \end{array} \quad (17)$$

We summarise the first and most important result: $e_1^2 = e_2^2 = e_3^2 = Id, e_4^2 = -Id$. We have also verified the (anti)commutation relations for Clifford algebra $Cl_{3,1}$. As demanded by traditional mathematical physics, we could represent the iterants e, f , as well as the transpositions by 4 x 4 matrices

$$e := \begin{pmatrix} 1 & 0 & 0 & 0 \\ 0 & 1 & 0 & 0 \\ 0 & 0 & -1 & 0 \\ 0 & 0 & 0 & -1 \end{pmatrix}; \quad f := \begin{pmatrix} 1 & 0 & 0 & 0 \\ 0 & -1 & 0 & 0 \\ 0 & 0 & -1 & 0 \\ 0 & 0 & 0 & 1 \end{pmatrix}; \quad \varphi := \begin{pmatrix} 0 & 0 & 1 & 0 \\ 0 & 0 & 0 & 1 \\ 1 & 0 & 0 & 0 \\ 0 & 1 & 0 & 0 \end{pmatrix}; \quad \sigma \stackrel{\text{def}}{=} \begin{pmatrix} 0 & 1 & 0 & 0 \\ 1 & 0 & 0 & 0 \\ 0 & 0 & 0 & 1 \\ 0 & 0 & 1 & 0 \end{pmatrix}$$

What does this mean? The matrices e, f correspond (1) with the iterants or polarity strings, briefly, $[+ + - -]$, $[+ - - +]$. Logically these represent (2) two different atomic statements A and B in Boolean logic, also symbolised by (3) the icons \sqcap and \sqcup , which correspond with two idempotents in the Minkowski algebra, namely (4) $\sqcap \simeq f_1 + f_2$ and $\sqcup \simeq f_1 + f_4$. These two, simplest logic connectives, together with two transpositions of locations of characters, namely $\varphi := (1\ 3)(2\ 4)$, exchanging location 1 with 3 and 2 with 4; and $\sigma := (1\ 2)(3\ 4)$, exchanging location 1 with 2 and 3 with 4,

²⁴ See Schmeikal, "Four Forms Make a Universe," Table 17.

generate the basis not only of Minkowski space, but also of its 16-dimensional geometric algebra. Is not this a surprise? Two statements and two transpositions of characters in a linear fourfold array give rise to the basis of space-time geometry. We could represent this by matrices. The Minkowski space would thus be given by familiar 4 x 4 matrices:

$$e_1 = \begin{pmatrix} 1 & 0 & 0 & 0 \\ 0 & 1 & 0 & 0 \\ 0 & 0 & -1 & 0 \\ 0 & 0 & 0 & -1 \end{pmatrix}; \quad e_2 = \begin{pmatrix} 0 & 0 & 1 & 0 \\ 0 & 0 & 0 & 1 \\ 1 & 0 & 0 & 0 \\ 0 & 1 & 0 & 0 \end{pmatrix}; \quad e_3 = \begin{pmatrix} 0 & 0 & 0 & 1 \\ 0 & 0 & -1 & 0 \\ 0 & -1 & 0 & 0 \\ 1 & 0 & 0 & 0 \end{pmatrix}; \quad e_4 = \begin{pmatrix} 0 & 0 & -1 & 0 \\ 0 & 0 & 0 & 1 \\ 1 & 0 & 0 & 0 \\ 0 & -1 & 0 & 0 \end{pmatrix}$$

But, the more important result is that any dynamic process in space-time algebra can be processed line after line by manipulation of iterants with the circuits of autonomic intelligence.

Towards Line Processing of $SU(3) \subset Cl(3, 1)$

Using (15) and the imaginary unit i for convenience, we can compute a representation of the $SU(3)$ that can be written in one line instead of as matrices, in terms of transpositions φ, σ, τ combined with fourfold linear arrays, which means that the intellector needs two transposing swap gates, τ being immediately recognised as the present palindromic operation (19)

$$\begin{aligned} T_1 &= \frac{1}{4}\tau(Id - f) = \frac{1}{2}\tau[0,1,1,0] & T_2 &= \frac{i}{4}\tau(e - g) = \frac{i}{2}\tau[0,1, -1,0] \\ T_3 &= \frac{1}{4}(e - g) = \frac{1}{2}[0,1, -1,0] & T_4 &= \frac{1}{4}\varphi(Id - g) = \frac{1}{2}\varphi[0,1,0,1] \\ T_5 &= \frac{i}{4}\varphi(e - f) = \frac{i}{2}\varphi[0,1,0, -1] & T_6 &= \frac{1}{4}\sigma(Id - e) = \frac{1}{2}\sigma[0,0,1,1] \\ T_7 &= \frac{i}{4}\sigma(g - f) = \frac{i}{2}\sigma[0,0,1, -1] & T_8 &= \frac{1}{4\sqrt{3}}(e - 2f + g) = \frac{1}{2\sqrt{3}}[0,1,1, -2] \end{aligned}$$

These expressions resemble up to a factor $\frac{1}{2}$ the Gell-Mann matrices. In the corresponding matrix representation, we would consider zero in the first line and first column. What we need for line processing is the possibility of carrying out transpositions φ, σ, τ of four characters in line-arrays. On this basis, we can calculate $t-, u-$ and $v-$ spin. For example, let us calculate the isospin shift operators:

$$T_{\pm} = \frac{1}{\sqrt{2}}(T_1 \pm iT_2) = \frac{1}{2\sqrt{2}}(\tau[0,1,1,0] \mp \tau[0,1, -1,0]) \rightarrow T_+ = \frac{1}{\sqrt{2}}\tau[0,0,1,0] \quad (20)$$

and $T_- = \frac{1}{\sqrt{2}}\tau[0,1,0,0]$. Now verify the commutator equations for shift operators, first the product

$$\begin{aligned} T_3 T_+ &= \frac{1}{2\sqrt{2}}[0,1, -1,0]\tau[0,0,1,0] = \frac{1}{2\sqrt{2}}\tau[0, -1,1,0][0,0,1,0] = \frac{1}{2\sqrt{2}}\tau[0,0,1,0], \text{ next} \\ T_+ T_3 &= \frac{1}{2\sqrt{2}}\tau[0,0,1,0][0,1, -1,0] = \frac{1}{2\sqrt{2}}\tau[0,0, -1,0]; \text{ therefore, we obtain the commutator} \\ \llbracket T_3, T_+ \rrbracket &= T_3 T_+ - T_+ T_3 = \frac{1}{\sqrt{2}}\tau[0,0,1,0] = T_+ \text{ and likewise we get } \llbracket T_3, T_- \rrbracket = -T_- \quad (21) \end{aligned}$$

In this representation, the f_1 is a fixed lepton, and f_2, f_3, f_4 are quarks. We have

$$\begin{aligned} T_3 f_2 &= \frac{1}{2} [0, 1, -1, 0] [0, 1, 0, 0] = \frac{1}{2} [0, 1, 0, 0] = \frac{1}{2} f_2 \\ T_8 f_2 &= \frac{1}{2\sqrt{3}} [0, 1, 1, -2] [0, 1, 0, 0] = \frac{1}{2\sqrt{3}} [0, 1, 0, 0] = \frac{1}{2\sqrt{3}} f_2 \end{aligned} \quad (22)$$

The eigenvector $f_2 = [0, 1, 0, 0]$ corresponds to a state $|\mu\rangle$, where $\mu = (\mu_1, \mu_2) = \left(+\frac{1}{2}, +\frac{1}{2\sqrt{3}}\right)$ is distinguished by its eigenvalues under the operators T_3, T_8 of the Cartan subalgebra of $SU(3, \mathbb{C})$. We also have that

$$\begin{aligned} T_3 f_3 &= \frac{1}{2} [0, 1, -1, 0] [0, 0, 1, 0] = -\frac{1}{2} [0, 0, 1, 0] = -\frac{1}{2} f_3 \\ T_8 f_3 &= \frac{1}{2\sqrt{3}} [0, 1, 1, -2] [0, 0, 1, 0] = \frac{1}{2\sqrt{3}} [0, 0, 1, 0] = \frac{1}{2\sqrt{3}} f_3, \text{ corresponding to the weight vector} \\ \mu' &= \left(-\frac{1}{2}, +\frac{1}{2\sqrt{3}}\right), \text{ and finally} \end{aligned} \quad (23)$$

$$\begin{aligned} T_3 f_4 &= \frac{1}{2} [0, 1, -1, 0] [0, 0, 0, 1] = 0 \\ T_8 f_4 &= \frac{1}{2\sqrt{3}} [0, 1, 1, -2] [0, 0, 0, 1] = \frac{1}{2\sqrt{3}} [0, 0, 0, -2] = -\frac{1}{\sqrt{3}} f_4 \text{ for the weight vector} \\ \mu'' &= \left(0, +\frac{1}{\sqrt{3}}\right) \end{aligned}$$

Primitive idempotents f_2, f_3, f_4 can thus be identified with quark-states $|u\rangle, |d\rangle, |s\rangle$. Notice, that the Cartan algebra $\{T_3, T_8\}$ is a subalgebra of the Cartan algebra of the rank 3 symmetric unitary group $SU(4) \subset \mathbb{C} \otimes Cl_{3,1}$,²⁵ which is given by the three commuting multivectors $\{e_1, e_{24}, e_{124}\}$, or what we have abbreviated by $\{e, f, g\}$.

Words of LICO

When discussing dialectical machine vision, Isaacson performs a turnover from BIP to DIP phenomenology.²⁶ We are confronted with neural circuits, constituted by three types of neurons, namely, *type C – central*, *type P – peripheral*, and *type H – horizontal*. A CA DIP-cell is represented by a C-neuron surrounded by eight P-neurons in a regular arrangement.²⁷ In my paper “On Consciousness & Consciousness Logging Off Consciousness,”²⁸ I tried to go back in time to see what happened. DIP had begun with a 2D, 256-state Moore-neighbourhood cellular automaton. This was realised by a highly interacting network of BIPs. Inputs to DIP were some digitised images,²⁹ given by silhouettes of objects, so-called *retinels*, embedded in some ground, both represented by pixels with different grey values. The CA operated on the input image by carrying out an 8-way comparison of each pixel with its eight neighbours, giving a difference or no difference. Each single, 8-way comparison thus yielded one value out of $2^8 = 256$ possible ones. Each retinel was then written down by words in an ideographic *alphabet of the visual cortex* with 256 letter-shapes, each of which represented one of the

²⁵ The connection between $Cl_{3,1}$, $SU(4, \mathbb{C})$ and $SL(4, \mathbb{C})$ is described by Lie brackets in Chapter 2 of Bernd Schmeikal, *Primordial Space – Pointfree Space and Logic Case* (New York: Nova Science, 2012).

²⁶ Isaacson, “Dialectical Machine Vision,” 35.

²⁷ Ibid., Figure 13.

²⁸ Bernd Schmeikal, “On Consciousness & Consciousness Logging Off Consciousness,” www.researchgate.net/publication/289335467_On_Consciousness, January 2016, 11-15.

²⁹ See Isaacson, “Dialectical Machine Vision,” Figures 10 to 12.

possible relationships. These fonts resemble the 16 letters of the logic alphabet LICO. In my view, Isaacson’s resistance to describing DIP in neural terms, has a much more serious reason than those social entanglements affiliated with McCulloch, Pitts, Foerster and the Perceptron,³⁰ namely, the notable features of the retinoid neuronal system of consciousness follow a deeper template that is more fundamental than neural nets. Its realization by the process of nature is at least as simple as a CA of the type DIP. The ground template is provided by the process of space-time itself. Primordial space provides rules for the formation of elementary particles, atoms, chemical elements, biomolecules, and genetic code.

In my article “Free Linear Iconic Calculus - AlgLog Part 1,” I showed how the shapes of the iconic letters can be understood in two ways, namely (1) by studying the truth tables of the corresponding Boolean connectives, or (2) by simply representing each primitive idempotent of the $Cl_{3,1}$ by a bar in a little square. Each icon has an algebraic expression in terms of four primitive idempotents f_1, f_2, f_3, f_4 (see Column 4 of Table 2)³¹ of the Clifford algebra $Cl_{3,1}$ which span the colourspace ch_1 , and likewise as multivector in this linear commutative vector space (see Columns 5 and 7). Every icon can also be obtained by superimposing four icons, which represent the basis of this space.

Table 2: Correspondences in Algebra Structures for Logic Icons

Nr. icon	Boole	LICO letter	Idempotents f in $Cl_{3,1}$	f Rep in colourspace $ch_1 \subset Cl_{3,1}$	Polarity string	Deformed Polarity string Rep in colourspace ch_1
J_{01}	$A \wedge \neg A$	\square	0	0	$[- - - -]$	$-Id$
J_{02}	$A \wedge B$	$-$	f_1	$\frac{1}{4}(Id + e_1 + e_{24} + e_{124})$	$[+ - - -]$	$\frac{1}{2}(-Id + e_1 + e_{24} + e_{124})$
J_{03}	$A \wedge \neg B$	$ $	f_2	$\frac{1}{4}(Id - e_1 + e_{24} - e_{124})$	$[- + - -]$	$\frac{1}{2}(-Id + e_1 - e_{24} - e_{124})$
J_{04}	$\neg A \wedge \neg B$	$-$	f_3	$\frac{1}{4}(Id - e_1 - e_{24} + e_{124})$	$[- - + -]$	$\frac{1}{2}(-Id - e_1 - e_{24} + e_{124})$
J_{05}	$\neg A \wedge B$	$ $	f_4	$\frac{1}{4}(Id + e_1 - e_{24} - e_{124})$	$[- - - +]$	$\frac{1}{2}(-Id - e_1 + e_{24} - e_{124})$
J_{06}	A	\sqcap	$f_1 + f_2$	$\frac{1}{2}(Id + e_1)$	$[+ + - -]$	e_1
J_{07}	$\neg A$	\sqcup	$f_3 + f_4$	$\frac{1}{2}(Id - e_1)$	$[- - + +]$	$-e_1$
J_{08}	$A \equiv B$	\equiv	$f_1 + f_3$	$\frac{1}{2}(Id + e_{124})$	$[+ - + -]$	e_{124}
J_{09}	$A \not\equiv B$	\equiv	$f_2 + f_4$	$\frac{1}{2}(Id - e_{124})$	$[- + - +]$	$-e_{124}$
J_{10}	B	\sqcap	$f_1 + f_4$	$\frac{1}{2}(Id + e_{24})$	$[+ - - +]$	e_{24}
J_{11}	$\neg B$	\sqcup	$f_2 + f_3$	$\frac{1}{2}(Id - e_{24})$	$[- + + -]$	$-e_{24}$
J_{12}	$A \vee B$	\sqcap	$f_1 + f_2 + f_4$	$\frac{1}{4}(3Id + e_1 + e_{24} - e_{124})$	$[+ + - +]$	$\frac{1}{2}(Id + e_1 + e_{24} - e_{124})$
J_{13}	$\neg A \vee B$	\sqcup	$f_1 + f_3 + f_4$	$\frac{1}{4}(3Id - e_1 + e_{24} - e_{124})$	$[+ - + +]$	$\frac{1}{2}(Id - e_1 + e_{24} + e_{124})$

³⁰ Warren S. McCulloch and Walter Pitts, “A Logical Calculus of the Ideas Immanent in Nervous Activity,” *Bulletin of Mathematical Biology* 5, no. 4 (1943): 115-33; Heinz von Foerster, *Das Gedächtnis: Eine Quantenphysikalische Untersuchung* (Vienna: Franz Deuticke, 1948).

³¹ Bernd Schmeikal, “Algebra of Quantum Logic,” in *Clifford Algebras and their Application in Mathematical Physics*, ed. R. Ablamowicz and B. Fauser, (Boston: Birkhäuser, 2000), 219-41.

J_{14}	$A \vee \neg B$	\sqsupset	$f_1 + f_2 + f_3$	$\frac{1}{4}(3Id + e_1 - e_{24} + e_{124})$	[+ + + -]	$\frac{1}{2}(Id + e_1 - e_{24} + e_{124})$
J_{15}	$\frac{\neg A}{\vee \neg B}$	\sqsubset	$f_2 + f_3 + f_4$	$\frac{1}{4}(3Id - e_1 - e_{24} - e_{124})$	[- + + +]	$\frac{1}{2}(Id - e_1 - e_{24} - e_{124})$
J_{16}	$A \vee \neg A$	\square	$\sum_i^4 f_i = Id$	Id	[+ + + +]	$+Id$

We can write

$$ch_1 = span_{\mathbb{R}}\{Id, A, B, \equiv\} = span_{\mathbb{R}}\{\square, \sqsupset, \sqsubset, \square\} \simeq span_{\mathbb{R}}\{Id, e_1, e_{24}, e_{124}\}$$

For example, we can obtain the logic adjunction $A \vee B$ by superimposing the generating icons

$$A \vee B \simeq \square = \frac{1}{2}(\square + \sqsupset + \sqsubset - \square)$$

That is, we get three minus one on the upper bar, which, divided by two, gives one on the upper bar; one minus one on the lower bar, giving zero; two on the left bar divided by two, giving one bar on the left; and two divided by two, giving one bar on the right. Hence, the icon looks like \square . In analogous way, any of the 16 icons can be obtained from the four $\square, \sqsupset, \sqsubset, \square$. What is interesting is that these four can be represented by binary sequences or polarised strings or by logic circuits. The most important representation seems to be given by the XNOR gate, symbolised by the identifying connective \equiv , and one of the sequences, say [+ + - -] and the two swap gates. There is a special beauty in such a design, as the logic equivalence comes in as an element of both the carrier set and the binary operation. Hence, when we multiply A with B we actually have the expression

$$A B = [+ + - -][+ - - +] = [+ - + -] \text{ representing the identity } A \equiv B.$$

So we can span this invariant subspace ch_1 by one of two signals A, B and the identity machine:

1) generating base units

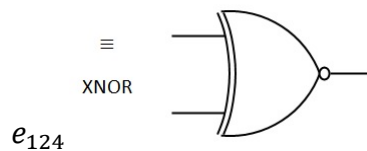
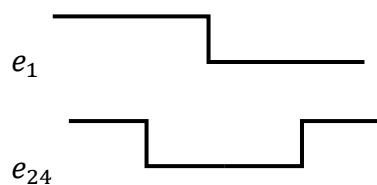

equivalent to the signal :

We need two swap gates to have the whole Clifford algebra of space-time. It is not a problem to imagine how these elements could be realised by neurons.

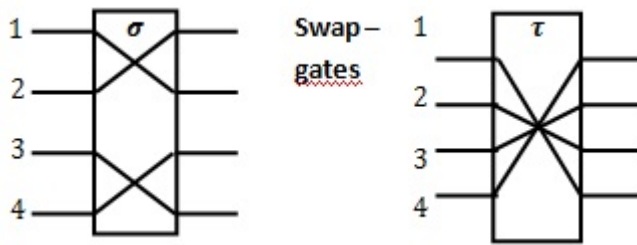

I would suggest that we design space-time the way we do it in Clifford algebra, because our brain functions in a way that prompts such a mathematical design. Surprisingly, Isaacson's BIP was indeed built up with the aid of such binary signals and by arrays of parallel XNOR gates, which is essential for the emergence of a Minkowskian space-time algebra. But I am missing one swap-gate that is necessary to iterate from the Cartan subalgebras. The BIP brings forth important features of the commutative subalgebras of the angular 4-momentum subspaces of HEPHY. Interpreted as articulations of neighbourhood, the icons of LICO describe a topological procedure operating on strings. We can apply LICO to LICO words. Then we obtain Hegelian cycles of recurring patterns of idempotent locations that may be interpreted as events in angular 4-momentum space, as dynamic processing of $SU(4)$ - and $SU(3)$ -multiplets (see Figure 5).

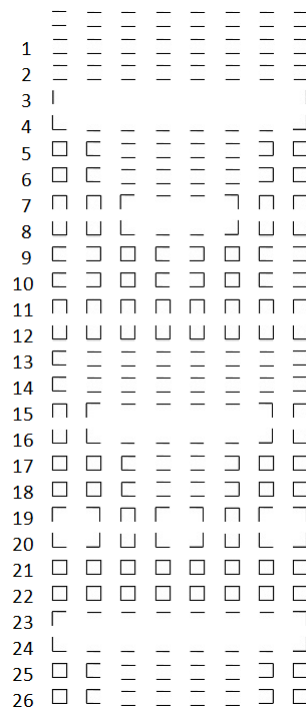

Figure 5: Recurring patterns of strings of idempotent locations.

This periodic pattern can also be generated by starting off from the second line of three empty neighbourhoods. Isaacson's discovery of how a simple cellular automaton unexpectedly encoded the baryon octet of elementary particle physics is not just a happy coincidence, but it is rooted in a deep archetypical connection between geometry and logic.³² We do not yet know where the journey goes, but it seems that the rigor completely works out.

Recursive Distinctioning and Antecursive Conflation

Isaacson and Kauffman have written a paper about what they call RD.³³ They have also written an advance statement as a letter in the *Journal of Space Philosophy*, to which I now refer.³⁴ This whole undertaking, which seems to carry on the torch of Hegelian dialectics, that is, limit cycles seen by a theory of dialectic cyclic development, may be fraught with problems philosophically, but seems serious mathematical business. It is also based on Kauffman's own work on recursion and distinction in cybernetics and his peculiar care for the investigations of George S. Brown into the *laws of form*.³⁵ Personally, I was not overmuch delighted by this darting off, since the two experts in *Hegelian Ansatz* seem to have neglected exactly one half of the dialectics and one half of the story of evolution, which has much of the quality of a fairy tale, anyway. In order to see the whole, I made a hotfoot invention of the dual process, that is, the *ante-cursive conflation*. To see what that is, imagine a UFO coming in from the horizon of your world. It looks like this:

³² Joel D. Isaacson, *Steganogramic Representation of the Baryon Octet in Cellular Automata*, (St. Louis, MO: IMI Corporation, 2015), www.isss.org/2001meet/2001paper/stegano.pdf (accessed December 8, 2015).

³³ *Journal of Space Philosophy* 5, no. 1 (Spring 2016): 9-63.

³⁴ Joel D. Isaacson and Louis H. Kauffman, "Recursive Distinguishing," *Journal of Space Philosophy* 4, no. 1 (2015): 23-27.

³⁵ Louis K. Kauffman, *Map Reformulation* (London: Princelet Editions, 1986).



```

314U1I
 1311141U1111I
    1113111111141111U311I
      311331113114311U13211I
        132123211113211413211U111312211I
          111312111213122111113122114111312211U31131122211I
            31131112311211131122211131131122211431131122211U1321132132211I
              111312111213122111113122114111312211U31131122211I
                132123211113211413211U111312211I
                  311331113114311U13211I
                    1113111111141111U311I
                      1311141U1111I
                        314U1I

```

As it approaches the egoistic centre of your world, its ideographic shape becomes a readable message, readable even in the familiar sense, from left to right, from top to bottom. But you cannot read it, because some rules that would provide the meaning are missing. Fortunately, a kid comes in and informs you that, at present, the **I** means 'I' as usual, that is, ego, and the **U** means you. **3 I** should denote a written sequence of three I's, that is, **III**, whereas **4 U** would stand for the sequence **UUUU**, that would be all. So you write down the 8-letter word

IIUUUUI

Being a philosopher, someone who likes wisdom, you can see the meaning of this word: It all has to begin with an invisible sentence, namely "I referring to m I self and I am referring to You and You are referring to Yourself and You are referring to me." So the top of the UFO "3 I 4 U 1 I" is a description of the line **IIUUUUI**. The next line should be a description of line **3 I 4 U 1 I**. Reading character by character, we see that we have one '3', that is, 1 3, further one **I**, that is, 1 I, further one '4', that is, 1 4, next 1 **U**, and so on. Altogether, we get 1 3 1 I 1 4 1 **U** 1 1 1 I. This provides the rule for the RD. Applying the rule many times, we obtain line after line following on from Invisible Line 1: I referring to m I self and I referring to You and you referring to Yourself and You referring to me.

Invisible Line 2: **I I I U U U U I**

Line 3: **3 I 4 U 1 I**

Line 4: **1 3 1 I 1 4 1 U 1 1 1 I** (Line 4 describing Line 3)

Line 5: **1 1 1 3 1 1 1 I 1 1 1 4 1 1 1 U 3 1 1 I**

Line 6: **3 1 1 3 3 1 1 I 3 1 1 4 3 1 1 U 1 3 2 1 1 I**

Line 7: word₁**I** word₂**You** word₃**I** (describing Line 6)

Recursive
D
i
s
t
i
n
g
u
i
s
h
i
n
g

It turns out that the domain of interpersonal experience (I and You) is transformed by mathematical self-reference/reflexive linguistic domain into a wilderness of numbers by which **I** and **U** are isolated from each other. There is some segregating demon in the mathematical detail. It seems that a wilderness of numbers is not necessarily essentially different from a wilderness of letters, is not essentially different from a wilderness of words, is not ... of sentences ... of threads and so on ad infinitum.

But now do the reverse! Now you have to be attentive for pairs of characters: 3 1 means '11' ...

For example, begin with: **3 1 1 3 3 1 1 I 3 1 1 4 3 1 1 U 1 3 2 1 1 I**

Line 6: **3 1 1 3 3 1 1 I 3 1 1 4 3 1 1 U 1 3 2 1 1 I**

Make 5: **1 1 1 3 1 1 1 I 1 1 1 4 1 1 1 U 3 1 1 I**

Make 4: **1 3 1 I 1 4 1 U 1 1 1 I**

Make 3: **3 I 4 U 1 I**

Make 2: **IIUUUUI**

Antecursive
C
o
n
f
l
a
t
i
o
n

By doing antecursive conflation, we get rid of the separating mass of numbers, and we are back at **U** and **I**. In this way, we obtain the lower half of the UFO converging towards our six letter word **3 I 4 U 1 I**.

3 1 1 3 1 1 1 2 3 1 1 2 1 1 1 3 1 1 2 2 2 1 1 I 3 1 1 3 1 1 2 2 2 1 1 4 3 1 1 3 1 1 2 2 2 1 1 U 1 3 2 1 1 3 2 1 3 2 2 1 1 I
 1 1 1 3 1 2 1 1 1 2 1 3 1 2 2 1 1 I 1 1 1 3 1 2 2 1 1 4 1 1 1 3 1 2 2 1 1 U 3 1 1 3 1 1 2 2 2 1 1 I
 1 3 2 1 2 3 2 1 1 I 1 3 2 1 1 4 1 3 2 1 1 U 1 1 1 3 1 2 2 1 1 I
 3 1 1 3 3 1 1 I 3 1 1 4 3 1 1 U 1 3 2 1 1 I
 1 1 1 3 1 1 1 I 1 1 1 4 1 1 1 U 3 1 1 I
 1 3 1 1 4 1 U 1 1 1 I
 3 I 4 U 1 I

What is important is to see the difference in **being aware for one definite character** while describing it by RD, and **being attentive for a relation**, that is, two characters, **while carrying out an antecursive conflation**. Future work will clarify this final issue of analysis.

About the Author: Bernd Anton Schmeikal, born May 15, 1946, a retired freelancer in research and development, qualified in Sociology with a treatise about cultural time reversal. He is a real maverick, still believing that social life can be based on openness and honesty. As a PhD philosopher from Vienna, with a typical mathematical physics background, he entered the trace analysis group of the UA1 Experiment at CERN, under the leadership of Walter Thirring, in 1965. This was in the foundation phase of the Institute for High Energy Physics (HEPhy) at the Austrian Academy of Science. He has always been busy solving fundamental problems concerning the unity of matter and space-time, the origin of the HEPHY standard model, and the phenomenology of relativistic quantum mechanics. In the Sociology Department of the Institute for Advanced Studies (HIS Vienna), he helped James Samuel Coleman to conceive his mathematics of collective action as a cybernetic system, and gave the process of *internalization of collective values* an exact shape. He implemented many transdisciplinary research projects for governmental and non-governmental organizations, universities and non-university institutions, and several times introduced new views and methods. He founded an international work stream that, for the first time, worked under the name of the Biofield Laboratory (BILAB). Although close to fringe science and electromedicine, the work of BILAB had a considerable similarity with the Biological Computer Laboratory run earlier by Heinz von Foerster. Lately, he has applied Foerster's idea of a universal relevance of hyperbolic distributions (Zipf's law) in social science to the labour market. This signifies a last contribution to the research program of the Wiener Institute for Social Science Documentation and Methodology (WISDOM) under the sponsorship of the Austrian Federal Presidential Candidate Rudolf Hundstorfer. He is convinced that a unity of science and culture can be achieved, but that this demands more than one Einstein. Consequently, he sought cooperation with Louis Kauffman and Joel Isaacson.



Editors' Notes: Dr. Bernd Schmeikal's review and evaluation of Joel D. Isaacson and Louis H. Kauffman's *Recursive Distinctioning* research and paper, published in this Journal, is a very valuable contribution to this forefront science investigation of *Nature's Cosmic Intelligence*. Dr. Schmeikal, University of Vienna Professor in mathematics, linguistics, and physics is one of the world's distinguished scholars for this special field of universe autonomous intelligence. He begins his abstract with the statement: "This paper investigates a universal creative system," and ends that abstract with "That is to say, our universe may be a representation of Isaacson's system, and entertainingly, with his US Patent specification 4,286,330, it seems he has patented creation." **Bob Krone and Gordon Arthur.**